

# BGDSF FIXED HEAD PAD DOCK SEAL

## FEATURES AND SPECIFICATIONS

Designed to suit 8' x 8' (2.4m x 2.4m) door openings, the BGDSF creates a tight, energy-efficient seal that keeps the loading dock area clean and safe while cargo handling takes place. It is a recommended solution when full access to the back of the trailer is not required.

After the trailer is positioned at the dock, two side pads and one head pad, all constructed from 99% memory foam, eliminate the gap between the building wall and the vehicle. Standard units seal trailers 12' to 13' high (3.6m to 3.9m) on a typical 4' (1.2m) dock height.

### STANDARD FEATURES:

- 10" (254mm) projection
- 22 oz. Hi-Tear vinyl base fabric
- Single head pad with the following dimensions: 10' (3m) wide x 10" (254mm) projection x 12" (305mm) high
- High visibility 24" (610mm) yellow guide stripe
- Waterproof wraparound design with vapour barrier
- Compression release holes
- Condensation draining vents
- 99% memory foam
- Galvanized mounting hardware

For maximum value and performance, the BDGSF can be constructed from our premium durability fabrics (see chart for materials, weights, and available colors).

### ADDITIONAL OPTIONS INCLUDE:

- 18" (457mm) high head pad to seal trailers up to 13.5' (4.1m) high
- 4", 8" or 16" (102mm, 203mm or 406mm) wear flaps to suit site requirements
- 12" (305mm) PVC drop curtain to enable a more effective seal for lower trailers
- Pressure-treated lumber

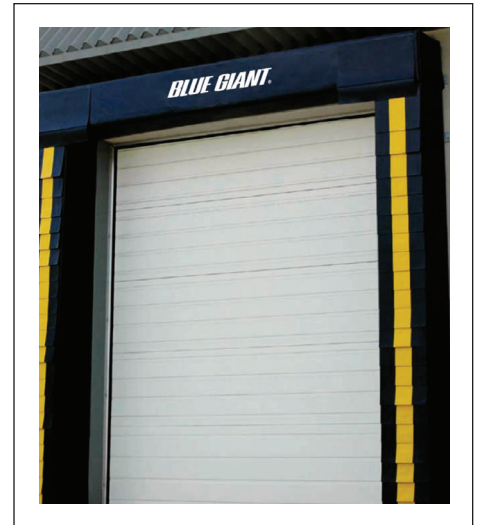
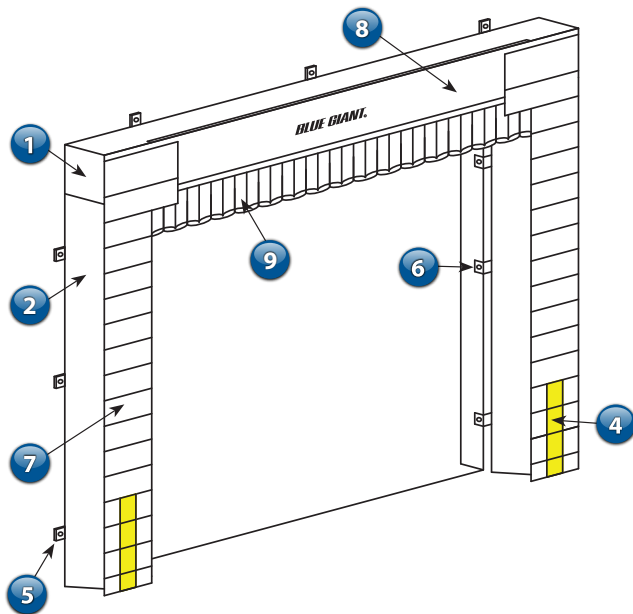

BGDSF Fixed Head Pad Dock Seal

### FABRIC AND COLOR SELECTION:

22oz Hi-Tear Vinyl	■	■	■	■
32oz Hi-Tear Vinyl	■			
40oz Hi-Tear Vinyl	■	■	■	■
50oz Hi-Tear Vinyl	■			
16oz Hi-Performance Hypalon	■			
40oz Hi-Performance Hypalon	■			

No.	DESCRIPTION
1	Head pad
2	Side pad
3	Wood backboard – Kiln dried †
4	4" x 24" (102mm x 610mm) yellow guide stripes
5	Flat bracket
6	Angle bracket
7	Wear flaps*
8	Double layer of fabric for reinforcement*
9	8" (203mm) Low temperature PVC drop curtain c/w 4" (102mm) overlap*

\*Some items displayed may be optional  
† Not shown on drawing

**BLUE GIANT**  
BLUE GIANT EQUIPMENT CORPORATION

**Corporate** 85 Heart Lake Road South  
Brampton, ON, Canada L6W 3K2  
t 905.457.3900 f 905.457.2313

**USA** 6350 Burnt Poplar Road  
Greensboro, NC 27409  
[www.BlueGiant.com](http://www.BlueGiant.com)

SS-BGDSF-022813

Blue Giant offers a full line of dock levelers, dock safety equipment, seals and shelters, accessories, ergonomic and scissor lift equipment and industrial trucks. Concurrent with our continuing product improvement program, specifications are subject to change without notice. Please contact Blue Giant for latest information. Some features illustrated may be optional in certain market areas.